

# EXTENS

**Minimalist podiatry chair equipped with 1 motor that controls height adjustment. Backrest and legrests independently adjustable by gas lift. Removable headrest cushion. White PU seamless upholstery of high quality that eases cleaning.**

Sillón de podología de diseño minimalista con 1 motor para regular la altura. Respaldo y reposapiés regulables independientemente mediante pistón de gas. Cojín reposacabezas extraíble. Tapizado blanco en PU sin costuras de alta calidad y fácil de limpiar.

Fauteuil de podologie de design minimaliste avec 1 moteur qui règle la hauteur du fauteuil. Inclinaison du dossier et hauteur des jambières réglables par vérin à gaz. Coussin repose-tête amovible. Revêtement en PU blanc sans coutures de haute qualité et facile à nettoyer.

*Fußpflegestuhl mit einem minimalistischen Design und mit einem Motor, um die Höhe zu regulieren. Rückenlehne und unabhängigen Fußstützen mittels Gasfeder regulierbar. Abnehmbares Kopfkissen. Hochwertige weiße PU-Polsterung ohne Nähte, leicht abwaschbar.*

*Poltrona podologica dal design minimalista. Dotata di 1 motore che regola l'altezza. Schienale e gambali indipendenti regolabili con pistoni a gas. Cuscino poggiatesta removibile. Rivestimento in PU bianco di alta qualità senza cuciture e facile da pulire.*

## Electric Podiatry Chair

Ref. 2232A.1.A26

Size without armrest: 190x56x60/78 cm

Size with armrest: 190x74,5x60/78 cm

Weight: 65 Kg

Upholstery: PU

Motors: 1

**1** Angle 45° ~ 85°

**2** Up and Down ±8 cm

**3** Up and Down 60/78 cm

**4** Angle 0° ~ 85°

**5** Extension ±15 cm

### OPTIONS

*Bed cover*

**6** *Foot controller* Ref. FC001/2232A

*Paper roll holder*

### PACKING SIZE cm

160x61x67

N.W. kg

65

G.W. kg

78

MAX WEIGHT

150 kg

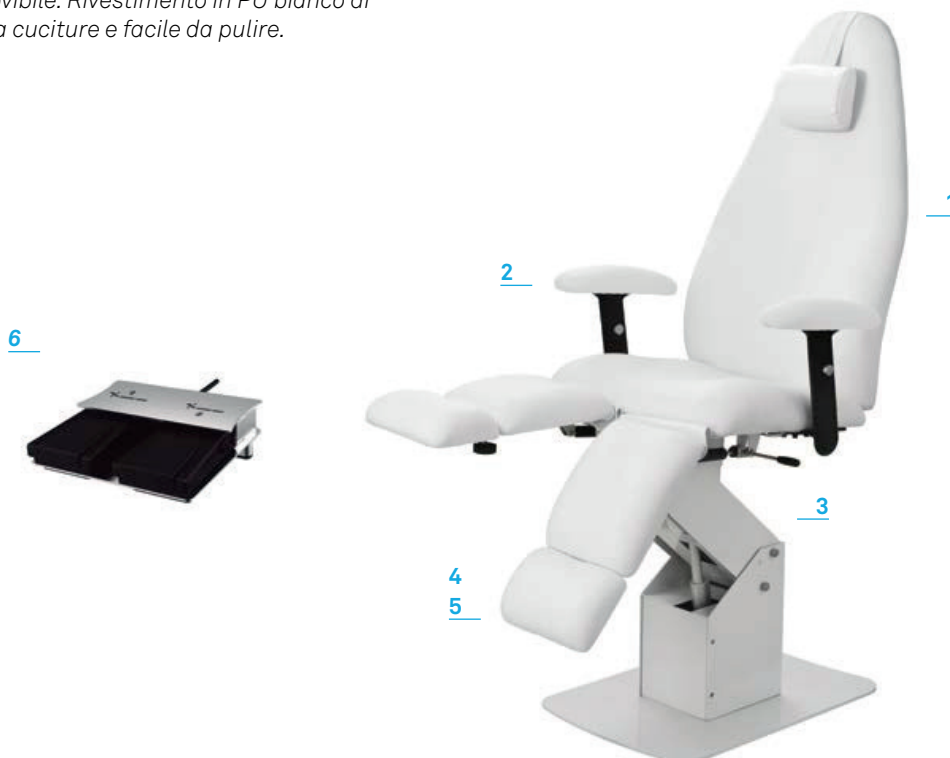

# EXTENS

